

Civil Engineer
SCHRICKEL, ROLLINS
AND ASSOCIATES, INC.
1161 CORPORATE DRIVE WEST
SUITE 200
ARLINGTON, TEXAS 76006
P: 817.649.3216

**Mechanical, Electrical,
Plumbing Engineer**
MEP SYSTEMS
918 DRAGON STREET
DALLAS, TEXAS 75207
P: 214.915.0929

Structural Engineer
RONALD A. ROBERTS ASSOCIATES, INC.
2948 N. STEMMONS FREEWAY
DALLAS, TEXAS 75247
P: 214.637.6299

Kitchen Consultant
PROFITABLE FOOD FACILITIES
14026 Donert Drive
POWAY, CALIFORNIA 92064
P: 858.748.7333

AV Consultant
ACHEVE AV, INC.
730 Ward Dr.
CEDAR HILL, TEXAS 75104
P: 214.884.9991

ARLINGTON
THE AMERICAN OCEAN CITY
**CHESTER W. BITTO GOLF COURSE
CLUBHOUSE**
CITY OF ARLINGTON
801 BROWN BLVD - ARLINGTON, TX 76011

No. | Date

Revisions

Project No. 21538.00

Drawn

Checked

Approved

Key:

PLAN NORTH

Architect

Engineer

Key:

Key:

Key:

Key:

Key:

Key:

Key:

Key:

Key:

Key:

Key:

Key:

Key:

Key:

Key:

Key:

Key:

Key:

Key:

Key:

Key:

Key:

Key:

Key:

Key:

Key:

Key:

Key:

Key:

Key:

© COPYRIGHT REES ASSOCIATES, INC. 2017

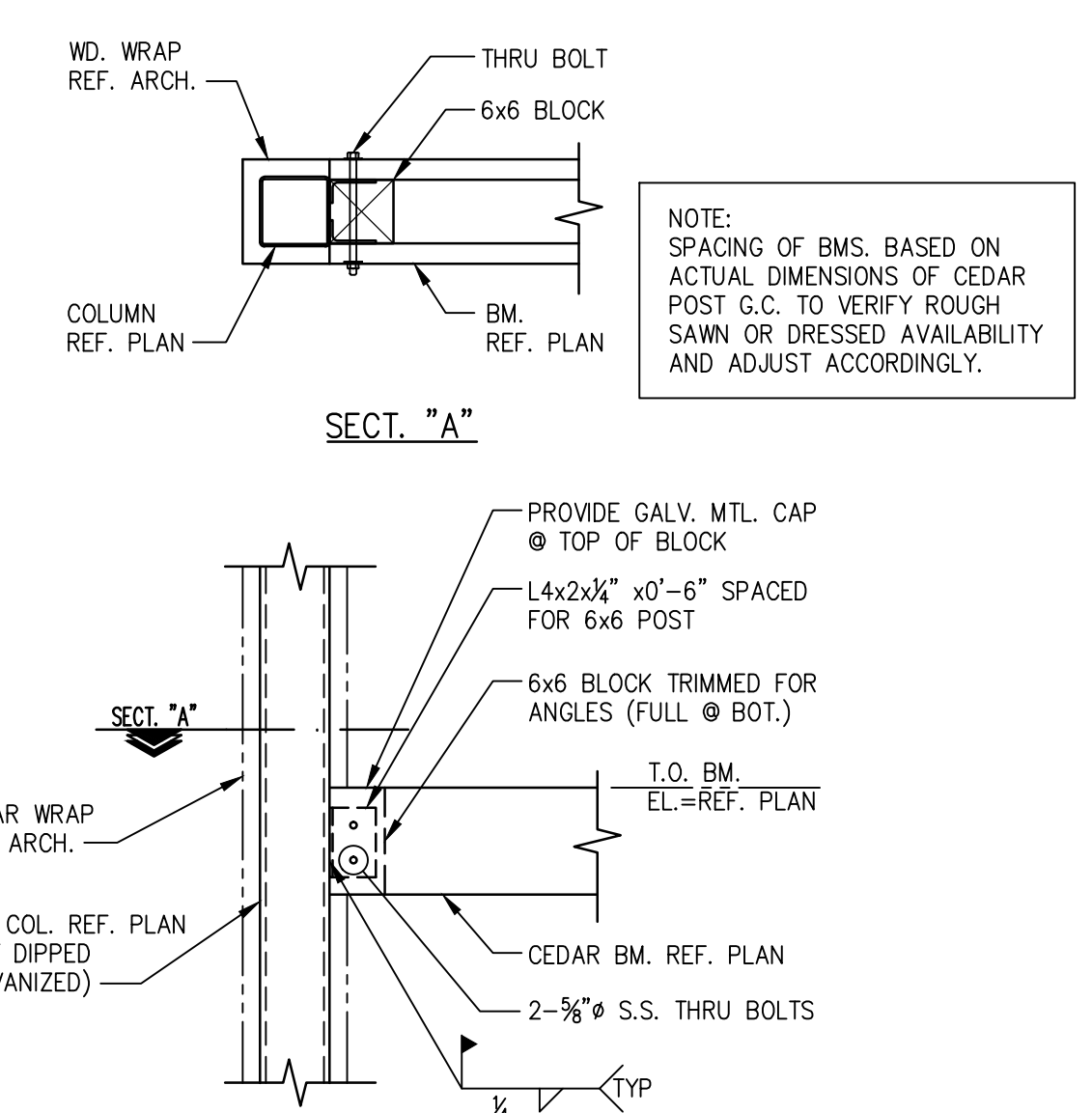

01 SECTION • TRELLIS
SCALE: 3/4"=1'-0"

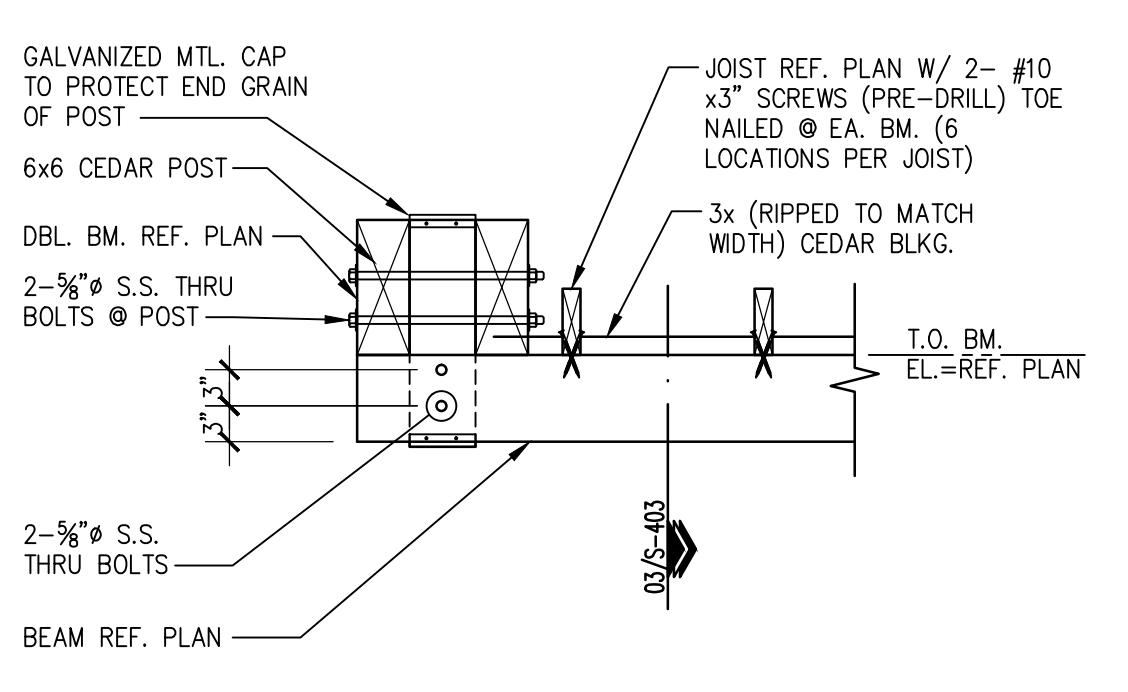

02 SECTION • TRELLIS
SCALE: 3/4"=1'-0"

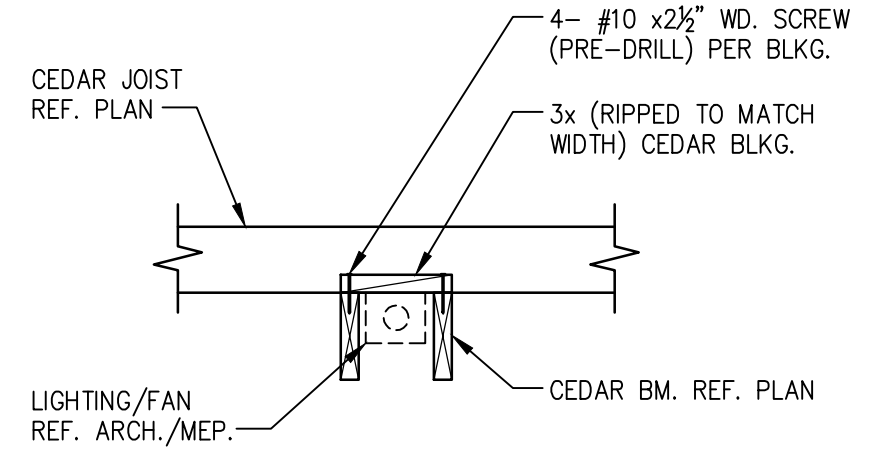

03 SECTION • TRELLIS
SCALE: 3/4"=1'-0"

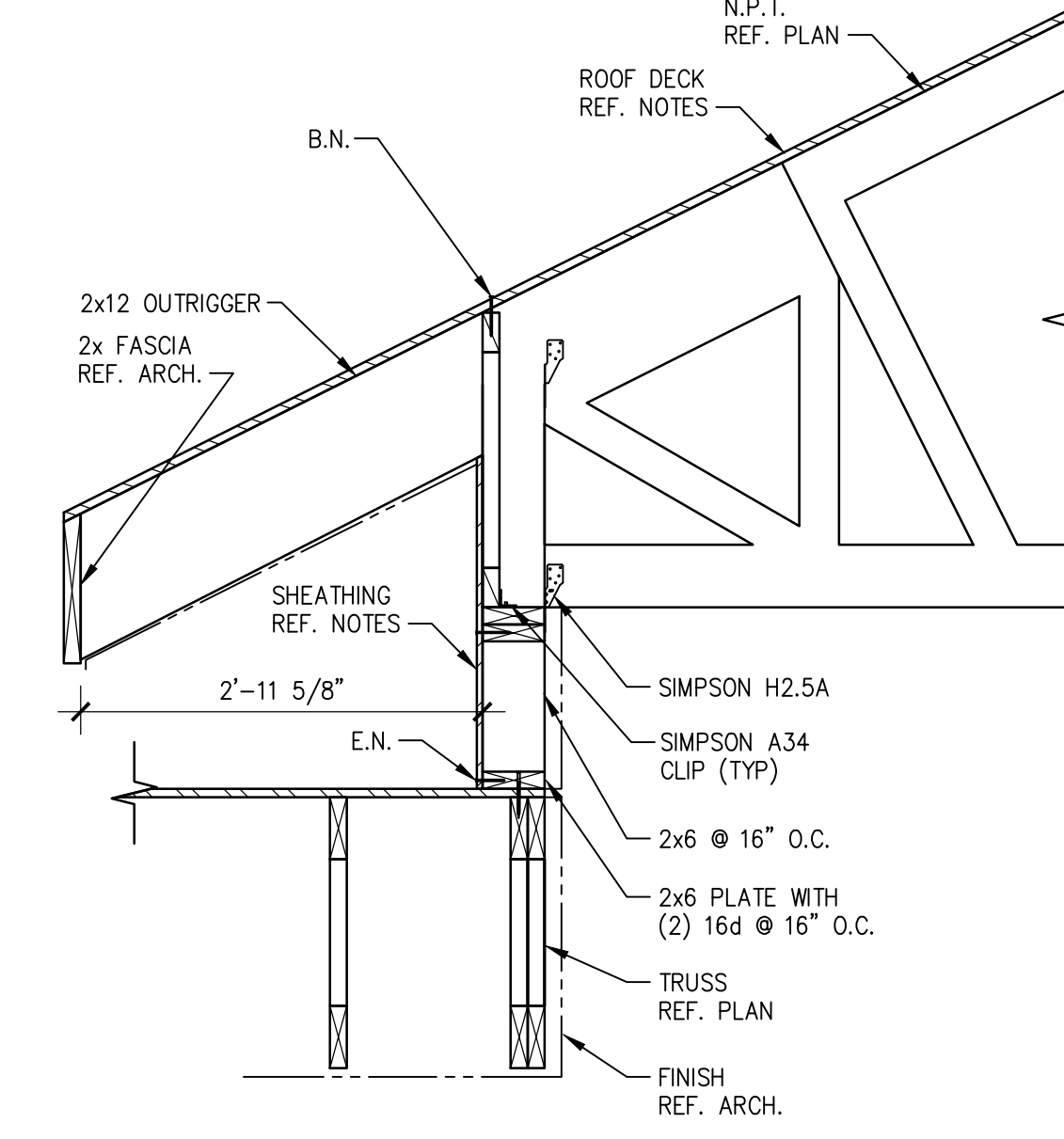

04 SECTION
SCALE: 3/4"=1'-0"

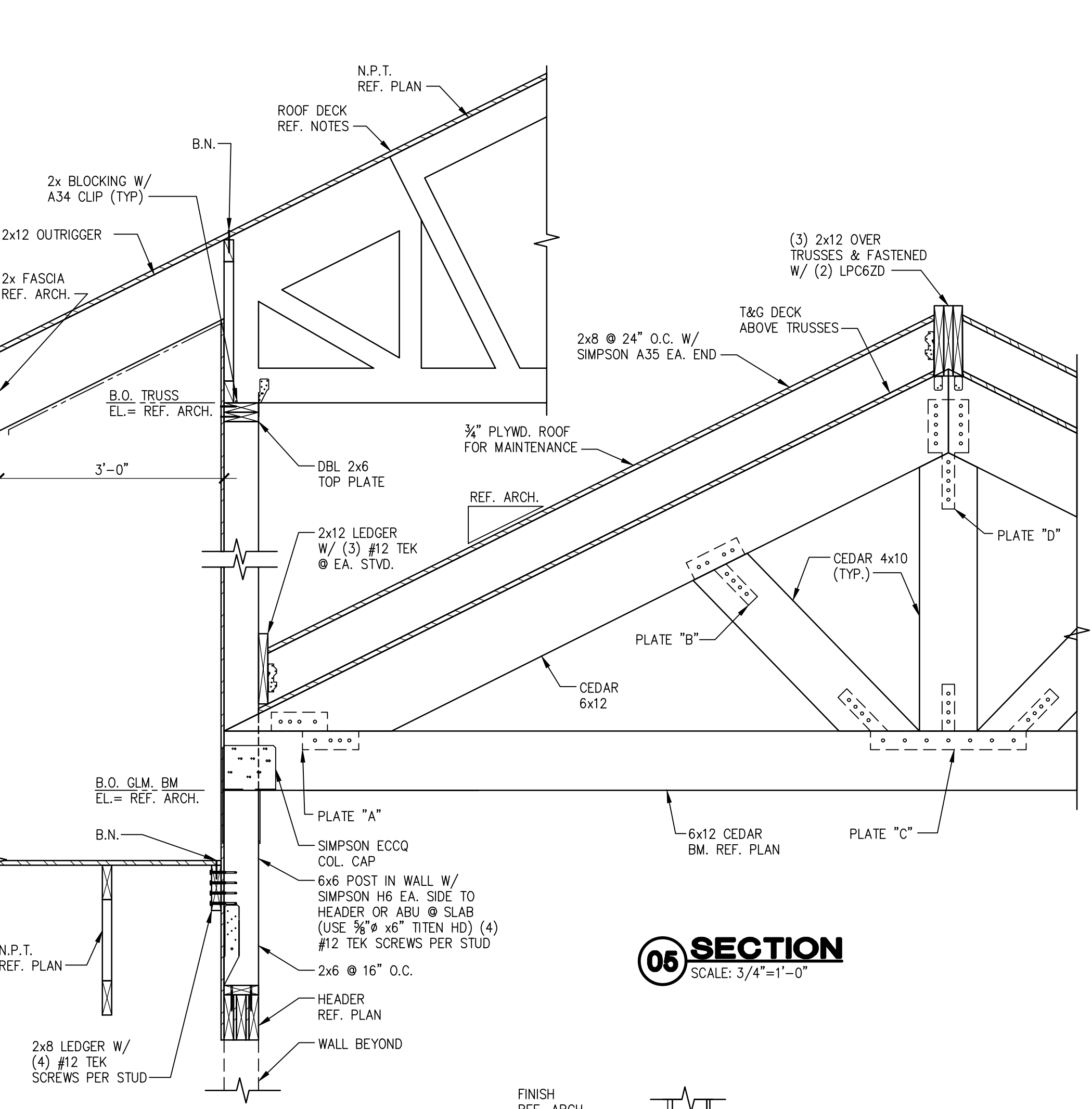

05 SECTION
SCALE: 3/4"=1'-0"

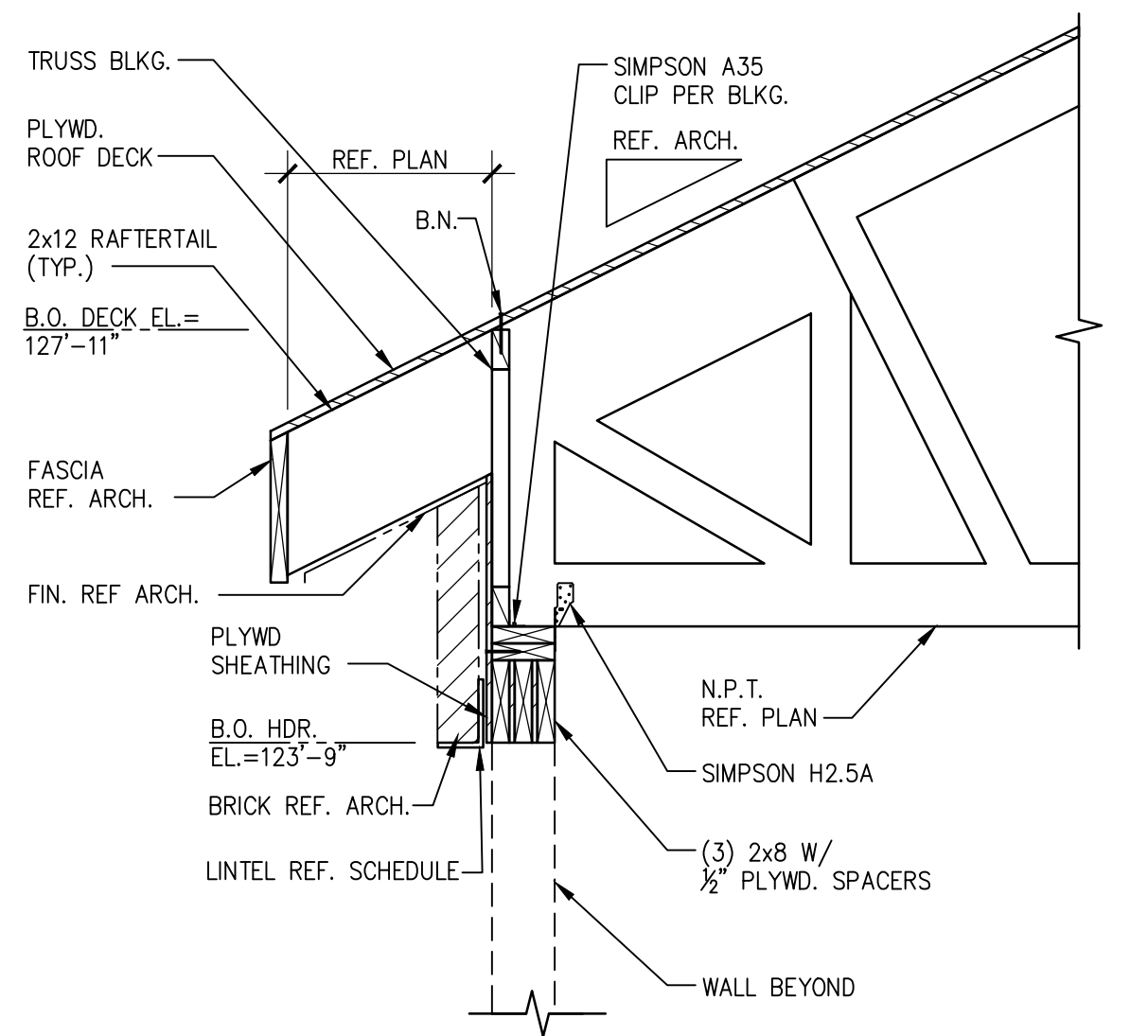

06 SECTION
SCALE: 3/4"=1'-0"

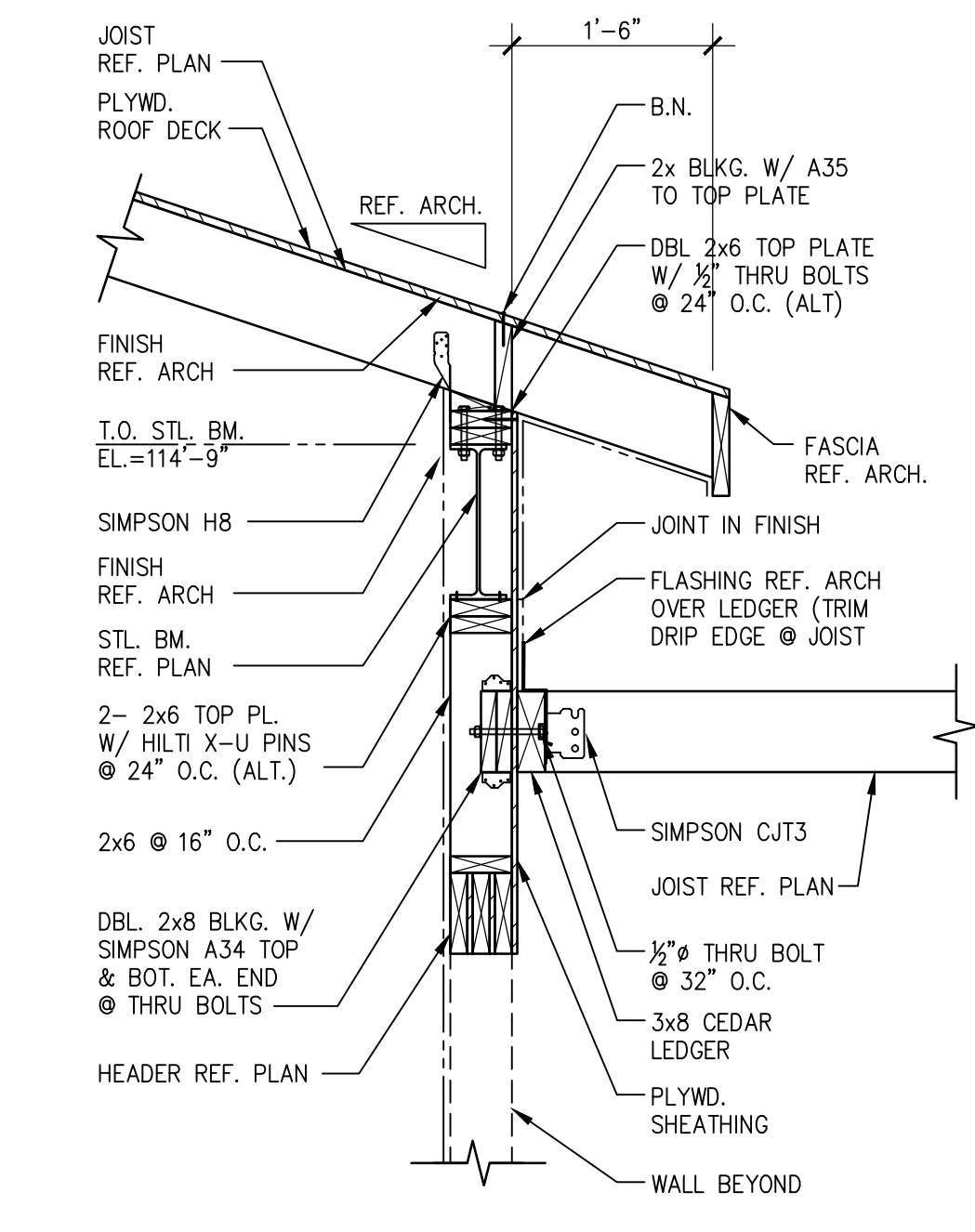

07 SECTION
SCALE: 3/4"=1'-0"

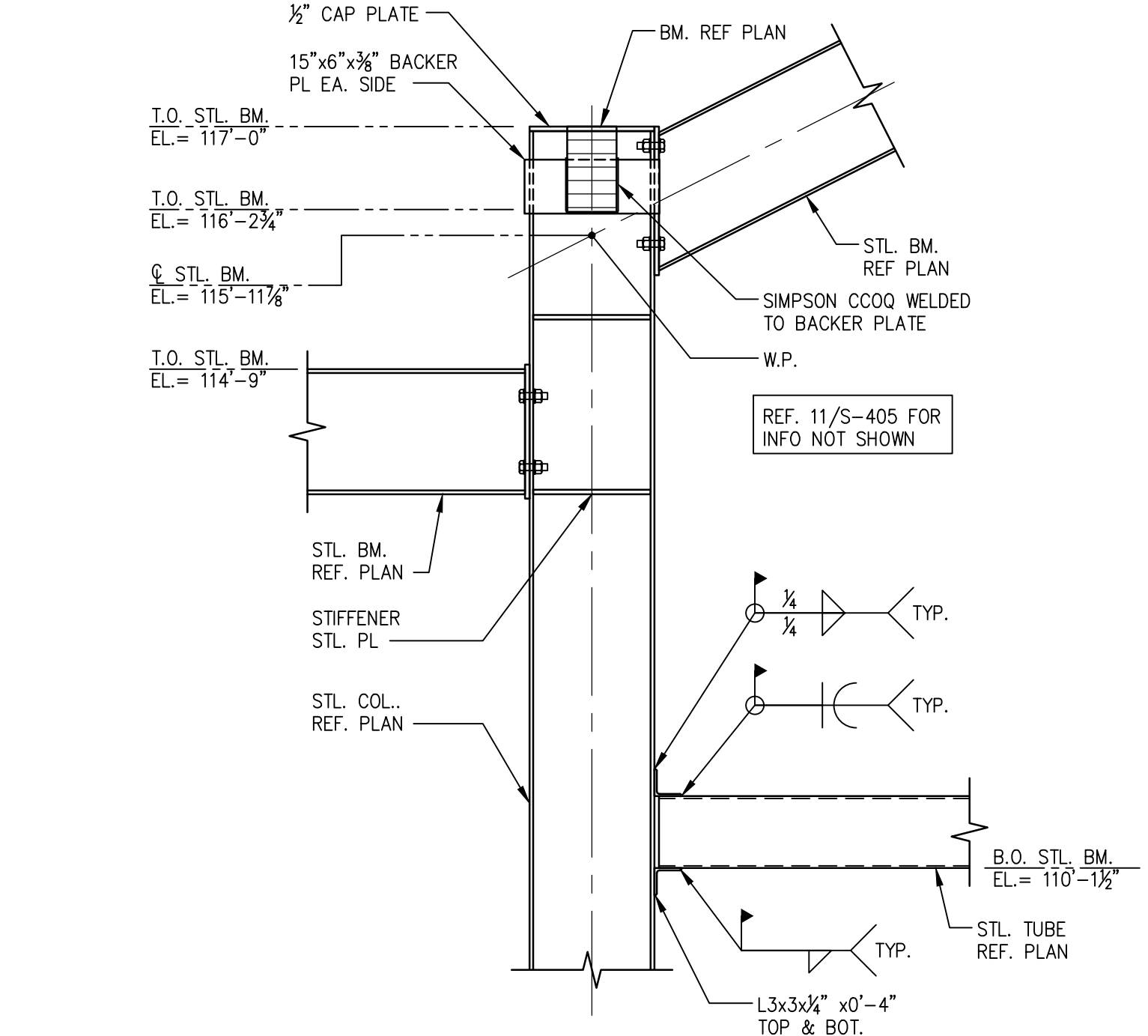

08 SECTION
SCALE: 3/4"=1'-0"

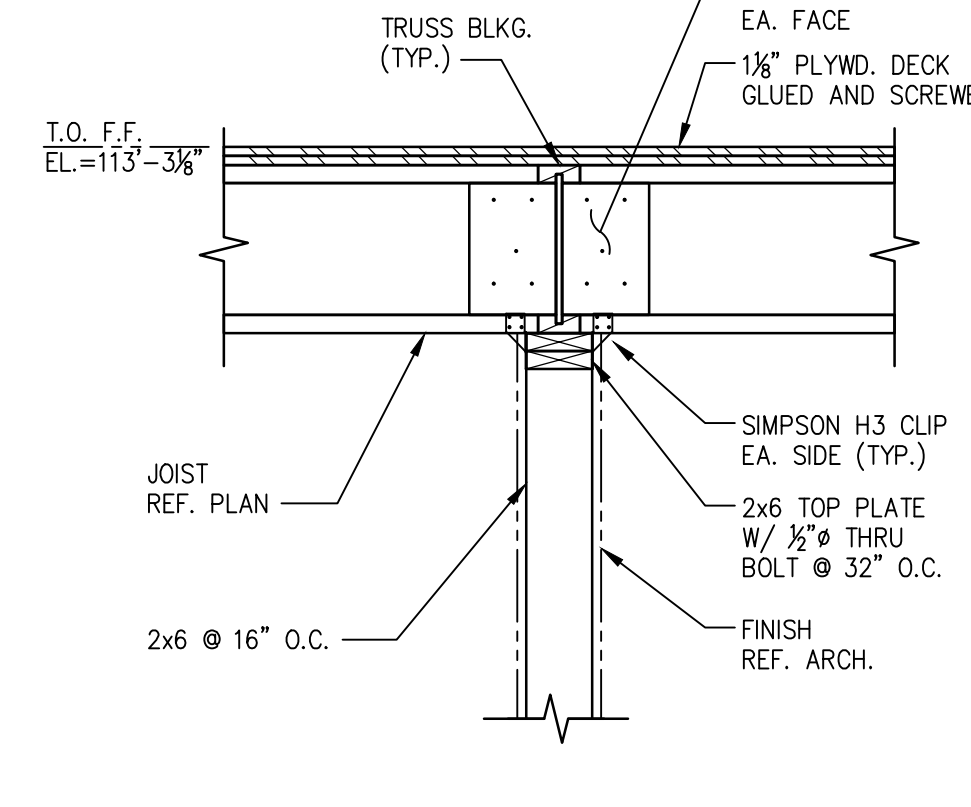

09 SECTION
SCALE: 3/4"=1'-0"

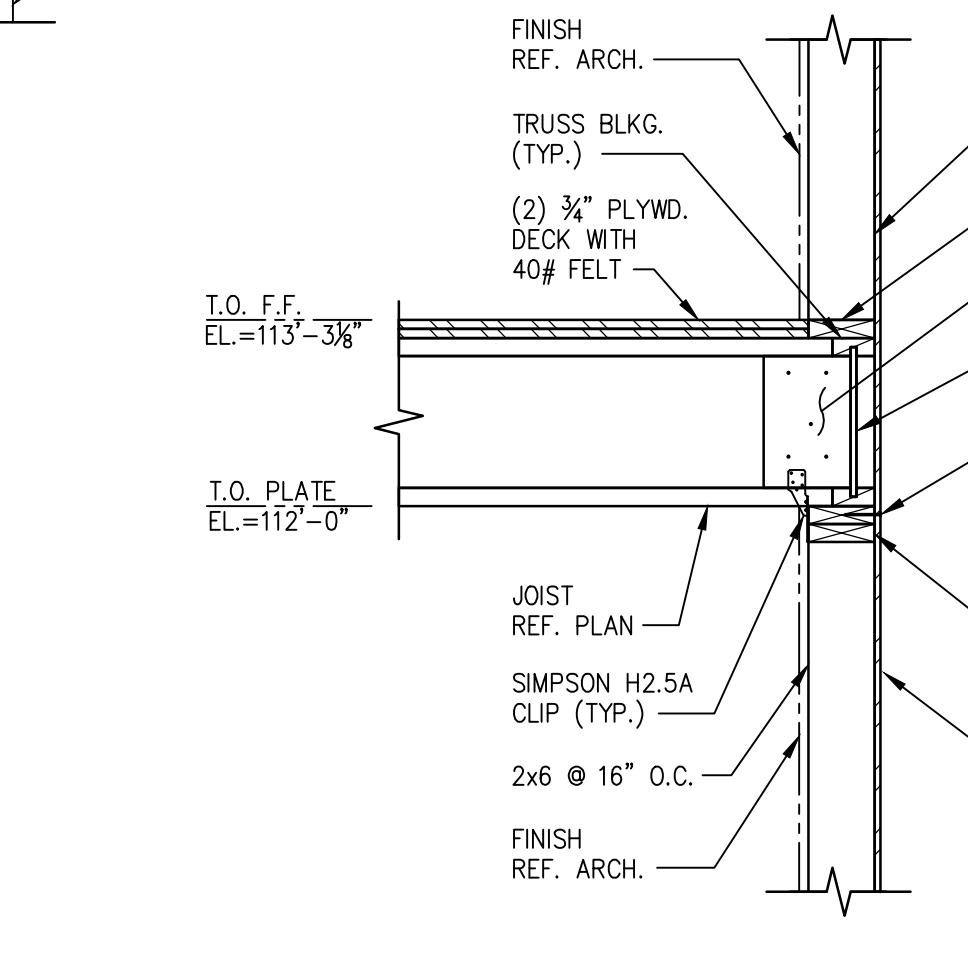

10 SECTION
SCALE: 3/4"=1'-0"

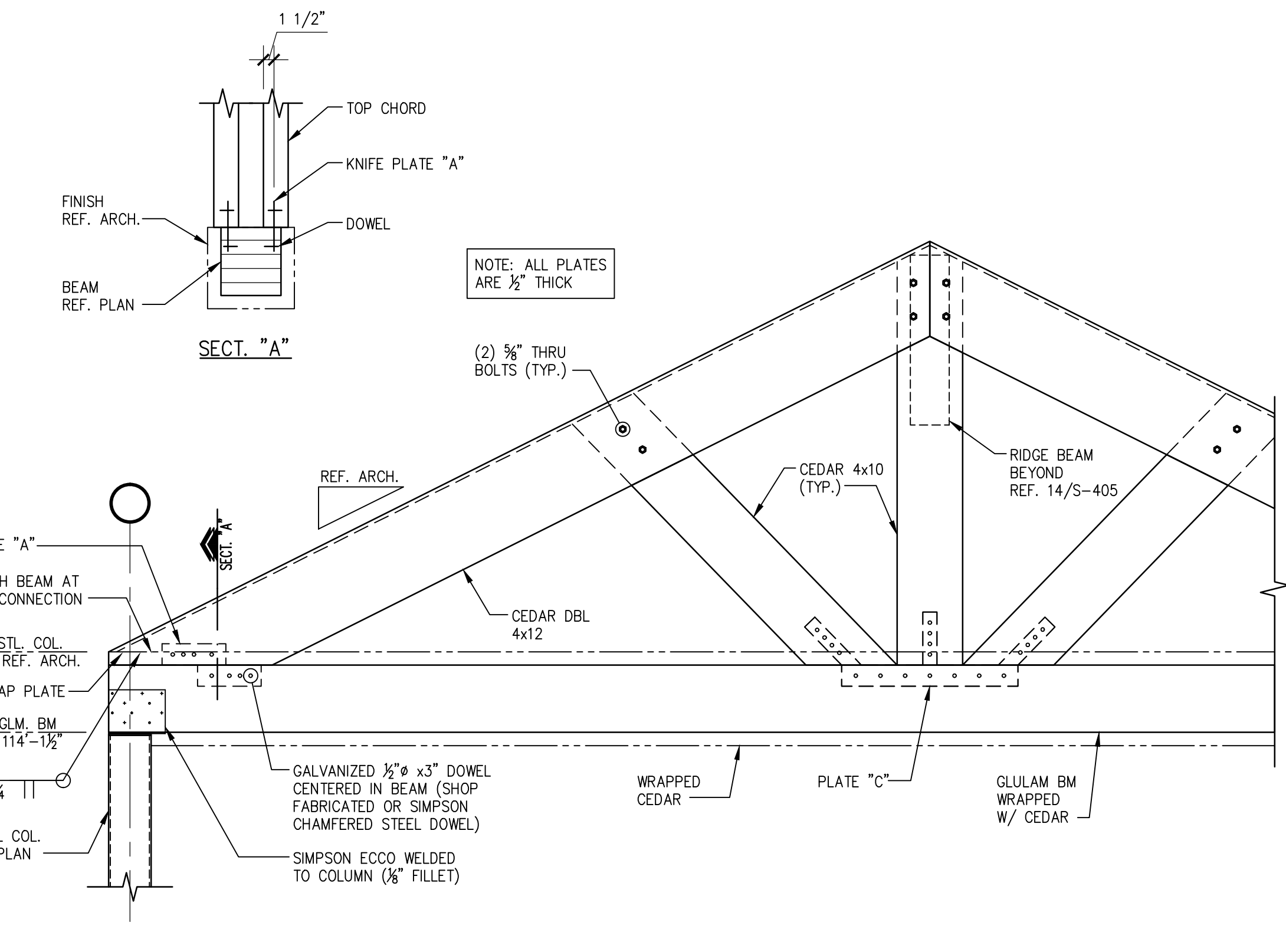

11 PARTIAL TRUSS ELEVATION
SCALE: 3/4"=1'-0"

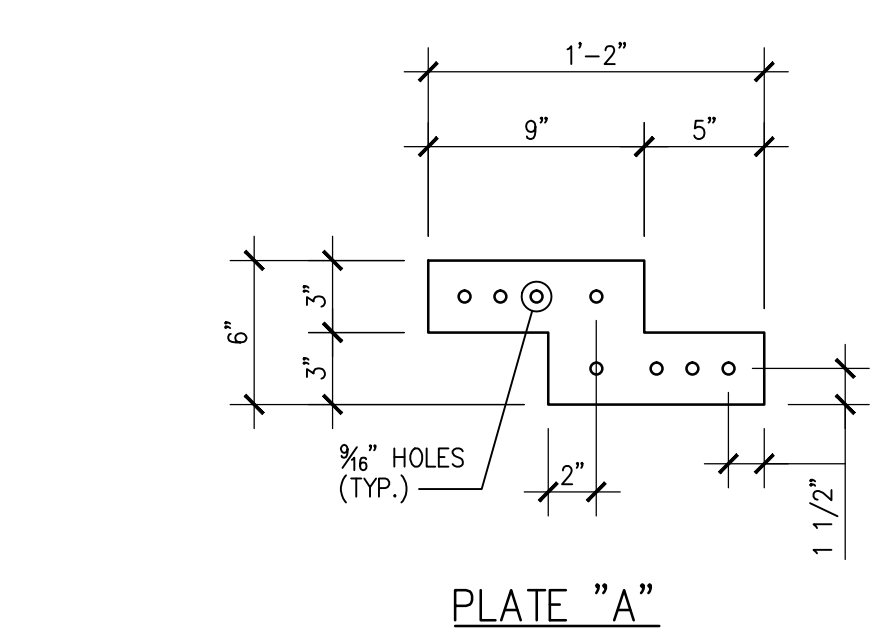

PLATE "A"

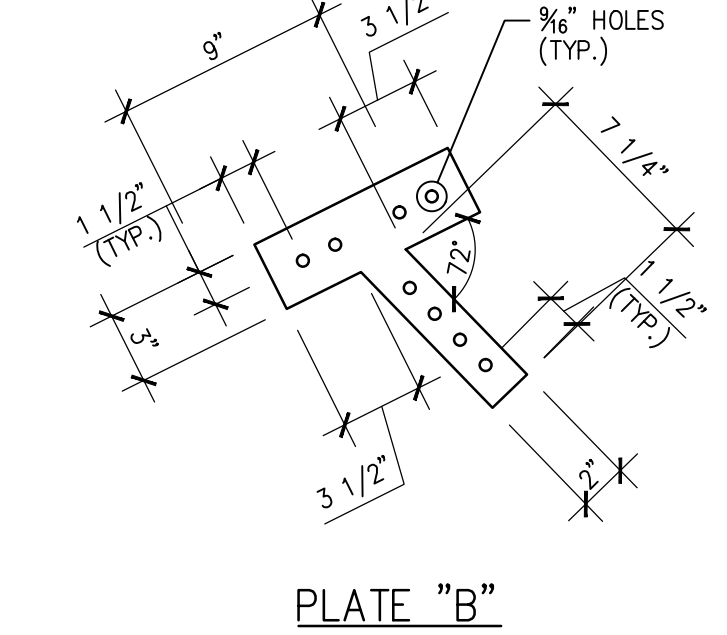

PLATE "B"

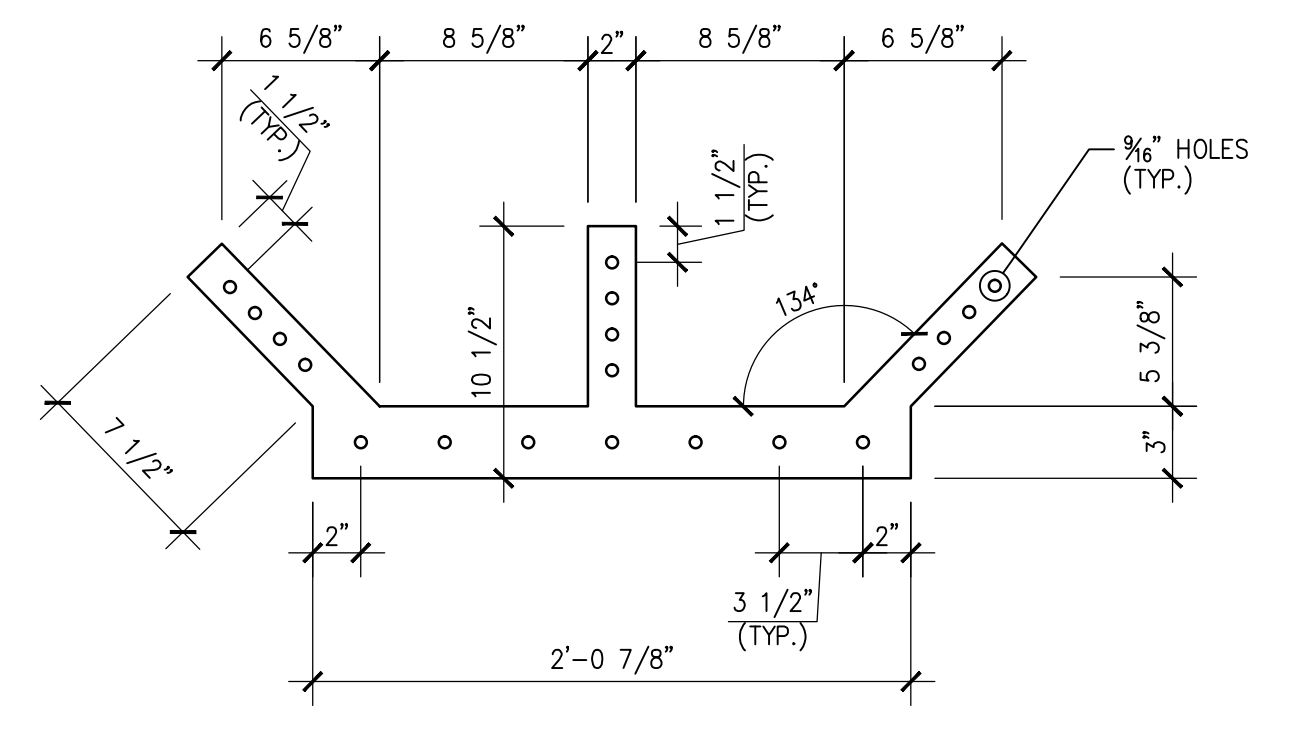

PLATE "C"

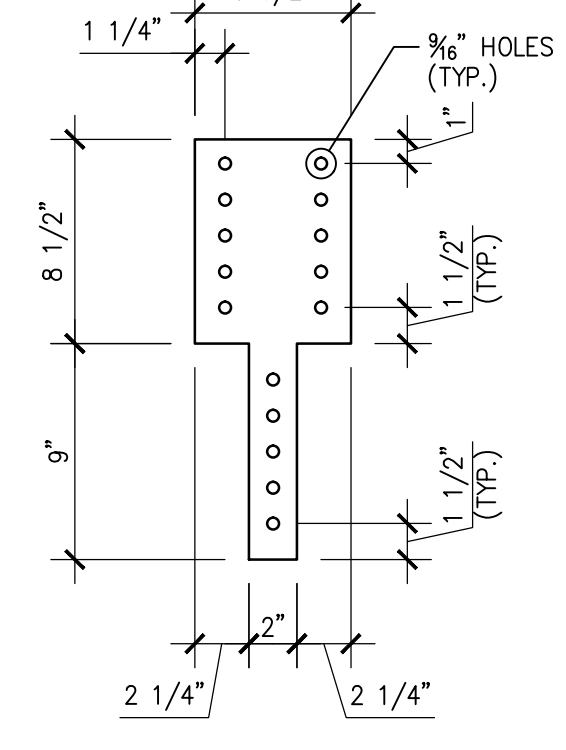
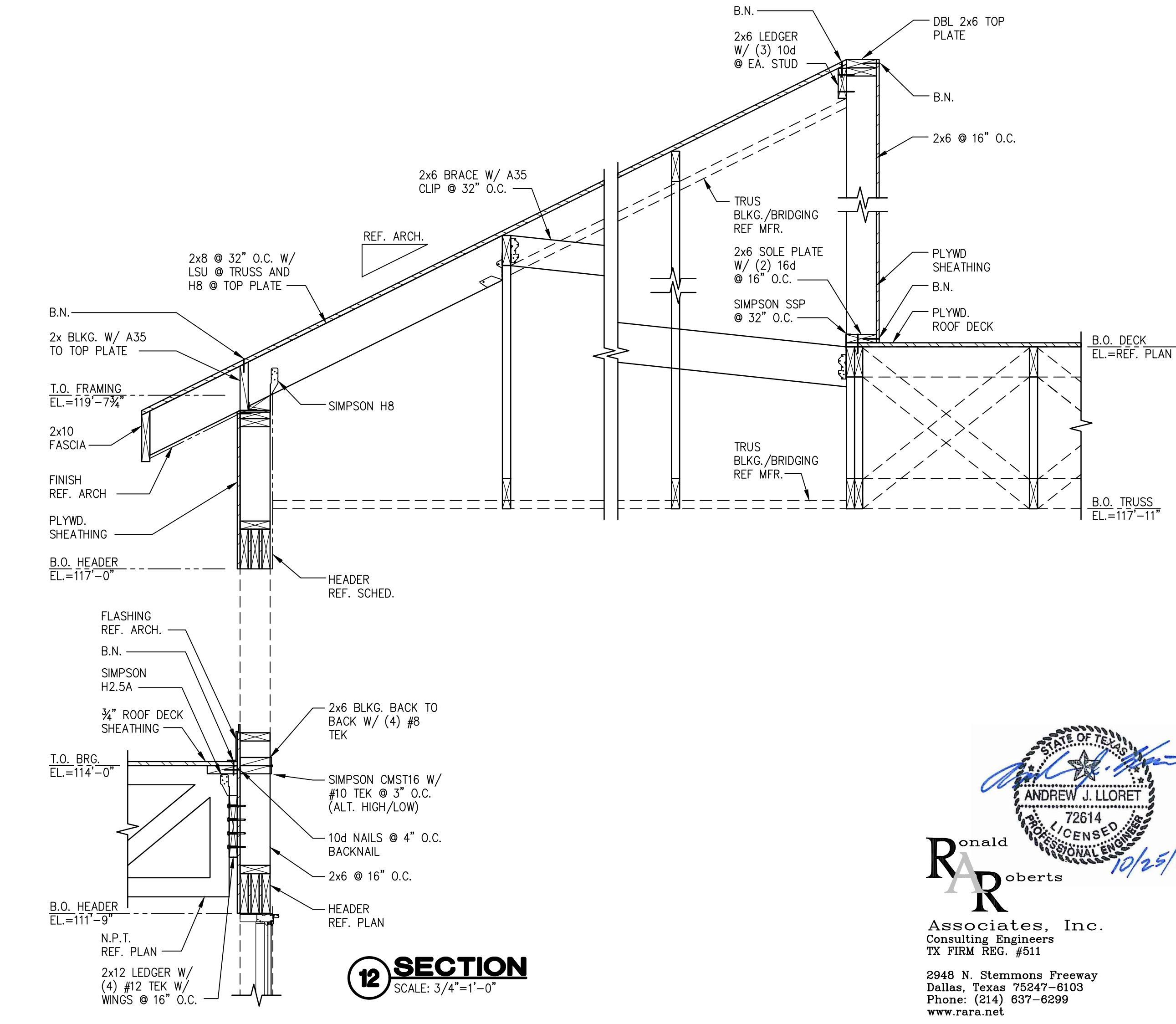

PLATE "D"



12 SECTION
SCALE: 3/4"=1'-0"

State of Texas
Professional Engineer
ANDREW J. LLORET
72614
10/25/17

Ronald A. Roberts
Associates, Inc.
Consulting Engineers
TX FIRM REG. #511

2948 N. Stemmons Freeway
Dallas, Texas 75247-0103
Phone: (214) 637-6299
www.rara.net

CONSTRUCTION DOCUMENTS

ROOF FRAMING DETAILS

Drawing No. **S-403**

Issue Date: OCTOBER 25, 2017