

24 May 2017
Sam Parron, P.E.
TX PE# 57170

DRAWINGS & SPECIFICATIONS ARE THE PROPERTY OF ENVIRODESIGN, INC. COPIES OF THE DRAWINGS & SPECIFICATIONS RETAINED BY THE CLIENT MAY BE UTILIZED ONLY FOR HIS USE & FOR OCCUPYING THE PROJECT FOR WHICH THEY WERE PREPARED, & NOT FOR THE CONSTRUCTION OF ANY OTHER PROJECT.

© 2017 ENVIRODESIGN, INC. ALL RIGHTS RESERVED. ALL DRAWINGS AND WRITTEN MATERIAL APPEARING HEREIN CONSTITUTE ORIGINAL AND UNPUBLISHED WORK OF THE ENGINEER AND MAY NOT BE DUPLICATED, USED OR DISCLOSED WITHOUT WRITTEN CONSENT OF ENVIRODESIGN, INC.

NOTE:
ALL TESTABLE CROSS-CONNECTION CONTROL DEVICE ASSEMBLIES SHALL BE APPROVED AND LOCATED SO AS TO BE ACCESSIBLE AND LOCATED WITHIN 5 FT. OF THE FINISHED FLOOR. EACH DEVICE SHALL BE CERTIFIED AT LEAST ANNUALLY AND THE RESULTS OF ALL TESTS SHALL BE AVAILABLE AT THE FACILITY.

RPZ VALVE SIZE	RPZ DRAIN SIZE	GPM @ 50 PSI
3/8"	1/2"	7 GPM
1/2"	3/4"	19 GPM
3/4"	1"	30 GPM
1"	1 1/4"	130 GPM
1 1/2"	2"	190 GPM

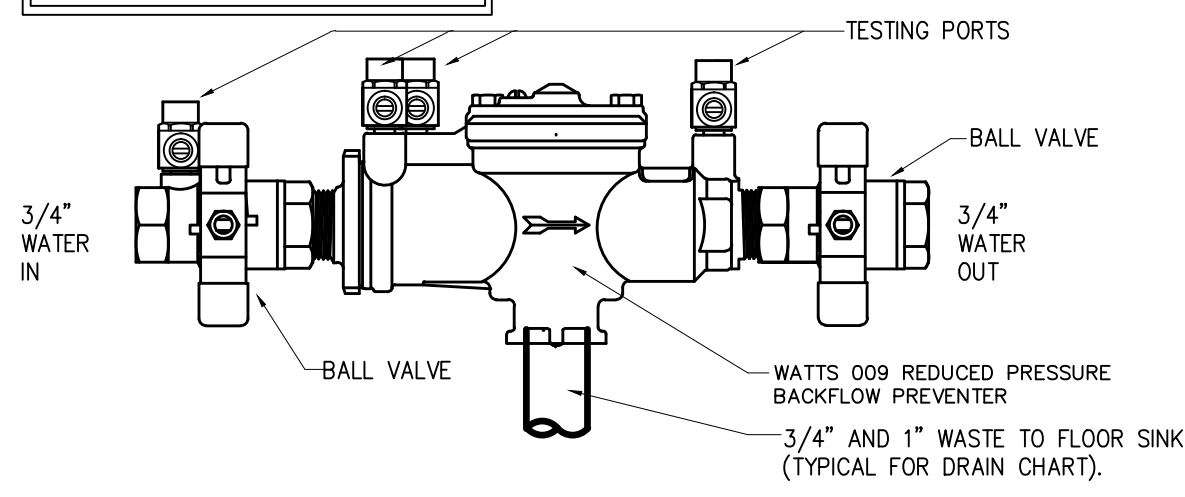

03 BACKFLOW PREVENTOR DETAIL
Scale: NOT TO SCALE

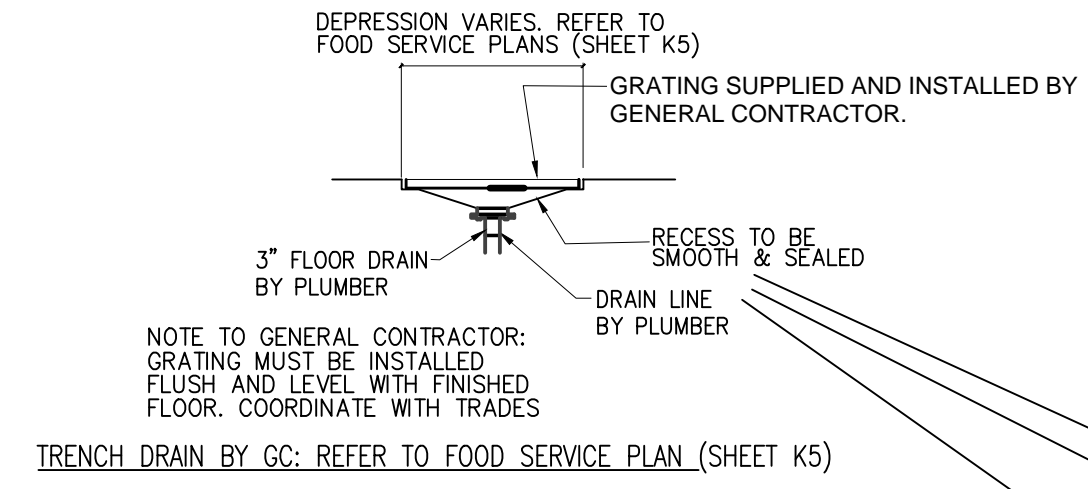

04 3-COMP. SINK DETAIL
Scale: NOT TO SCALE

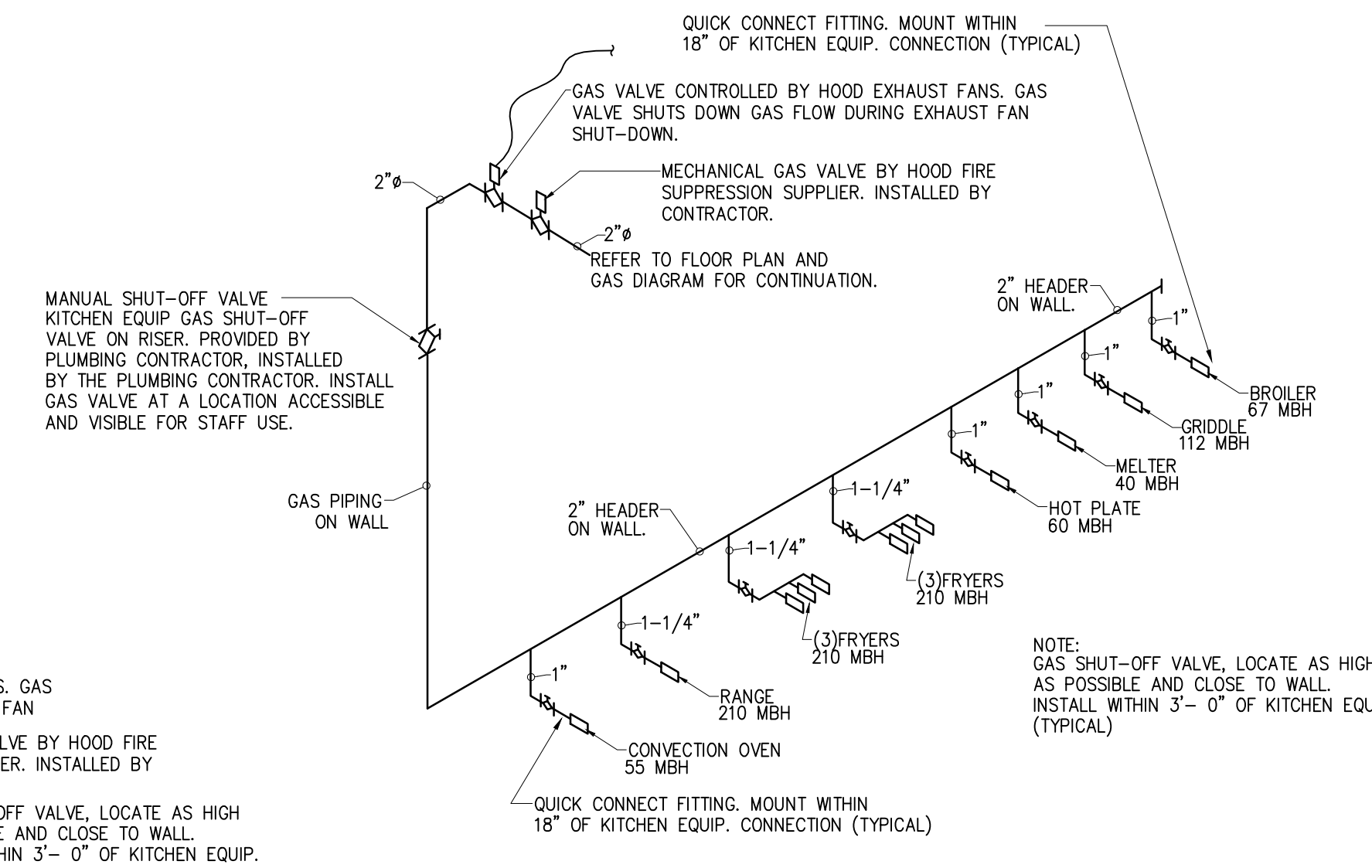

08 KITCHEN COOKLINE- GAS RISER
Scale: NOT TO SCALE

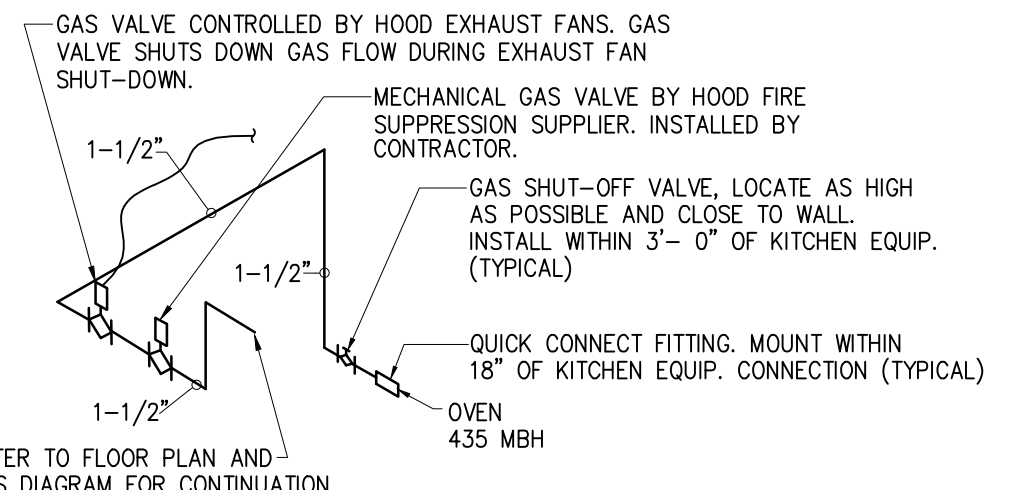

09 OVEN GAS RISER
Scale: NOT TO SCALE

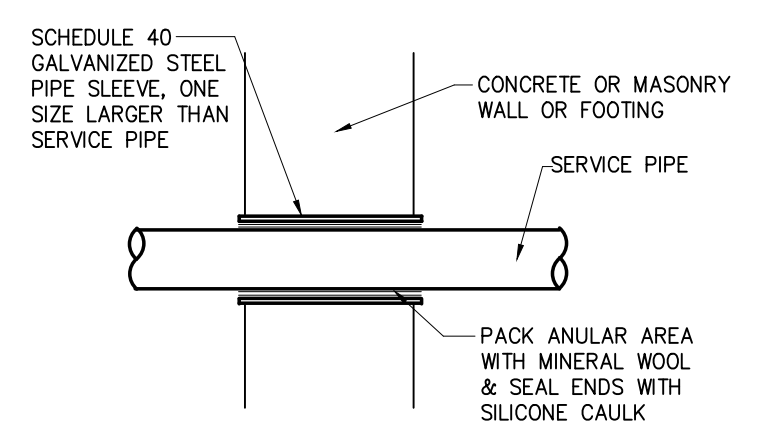

07 PIPE PENETRATIONS
Scale: NOT TO SCALE

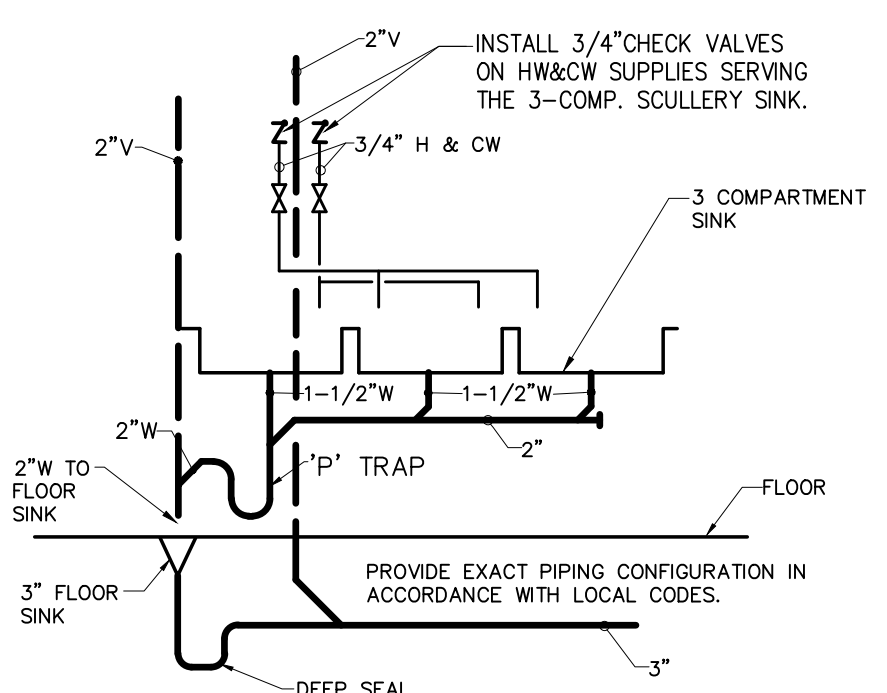

04 3-COMP. SINK DETAIL
Scale: NOT TO SCALE

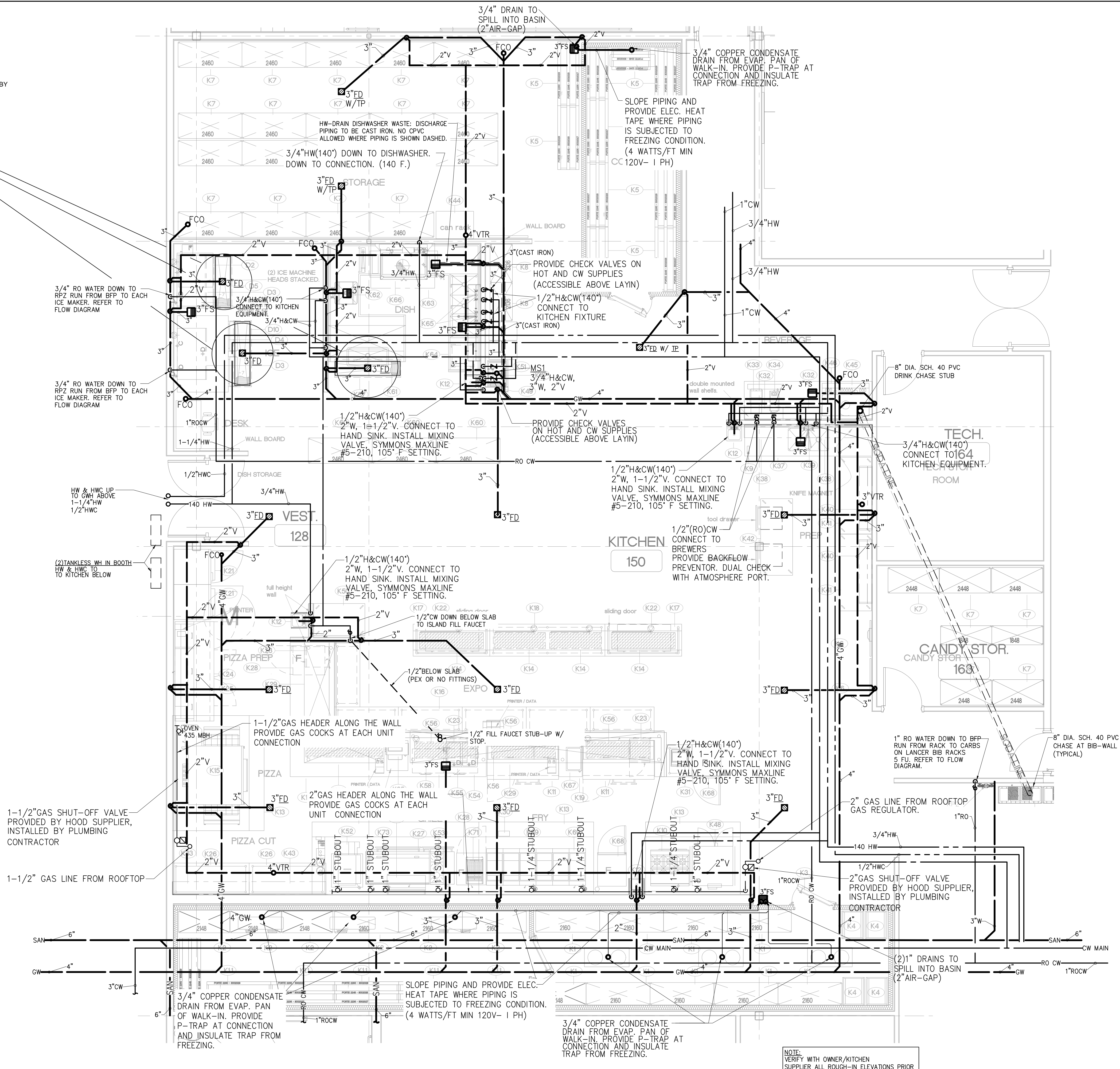

01 KITCHEN PLAN - PLUMBING
Scale: 1/4"=1'-0"

REV.	DATE	PERMIT ISSUE	ISSUE
5/12/17		PERMIT ISSUE	
5/24/17		ISSUE FOR BID	

Plotted By: ggrand 24 May 2017 Drawing File: F:\Dropbox (EnviroDesign)\EnviroDesign Team Folder\Current\2017-055 Cinergy Amarillo\2017-055P31.dwg