

F:\2015\15007\JEFF BENSON\CINERGY CINEMAS\AMARILLO\DRAWINGS\CIVIL CONSTRUCTION SHEETS\15-0071 C216 PAVING DETAILS.DWG

© COPYRIGHT 2014 ALL RIGHTS RESERVED

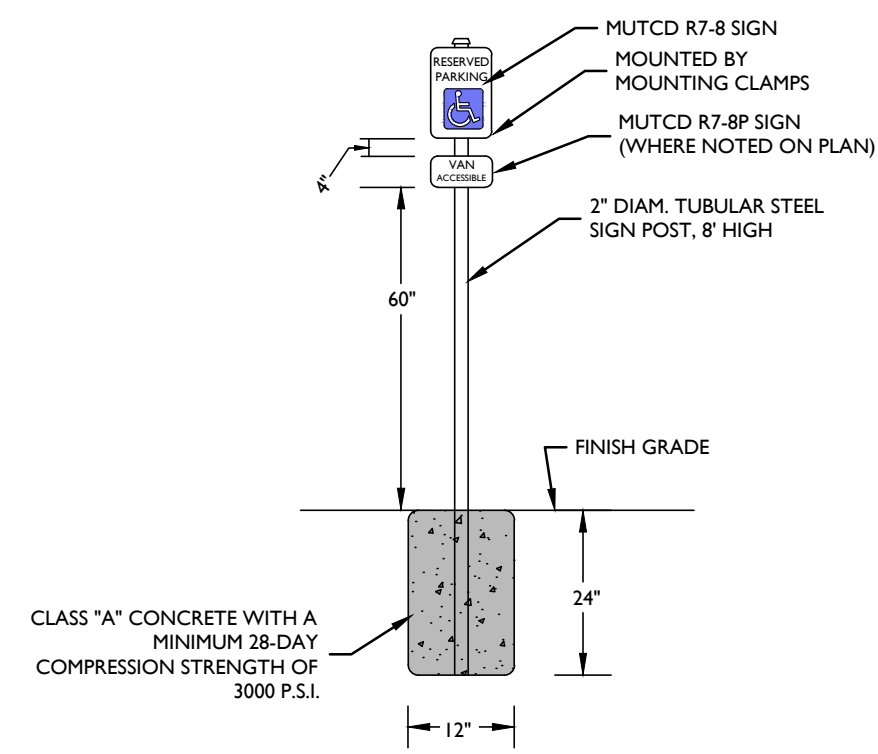

**ACCESSIBLE SIGN MOUNTING**  
OR APPROVED EQUAL. N.T.S.

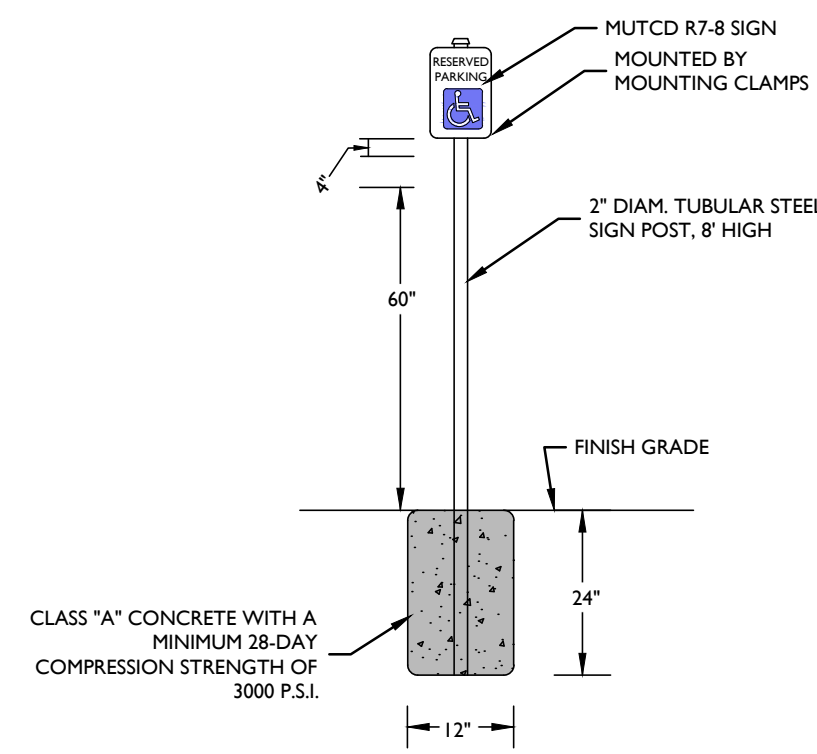

**ACCESSIBLE SIGN MOUNTING**  
OR APPROVED EQUAL. N.T.S.

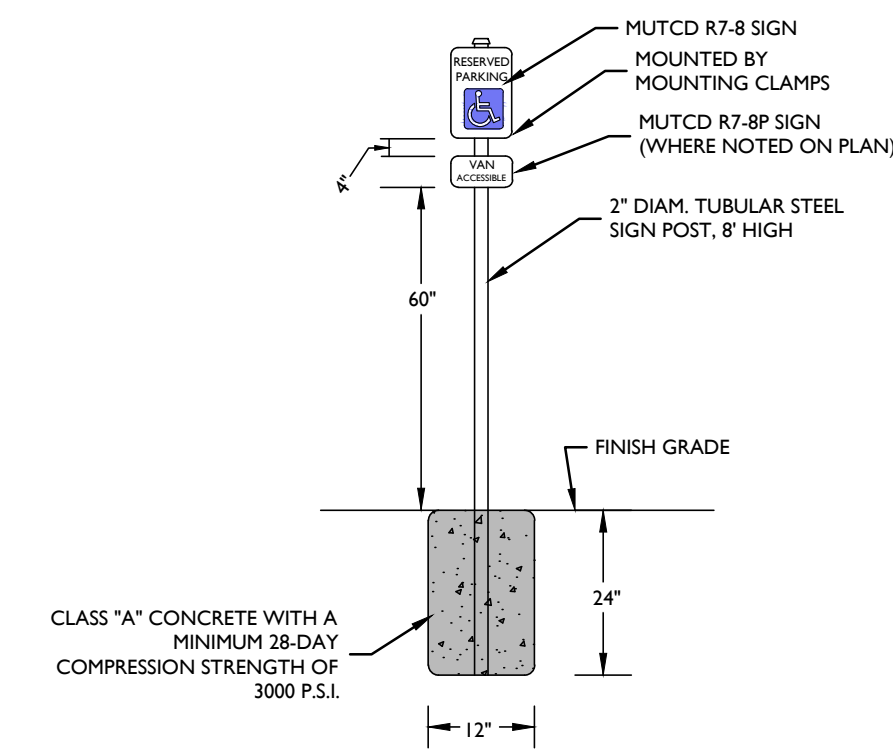

**ACCESSIBLE SIGN MOUNTING**  
OR APPROVED EQUAL. N.T.S.

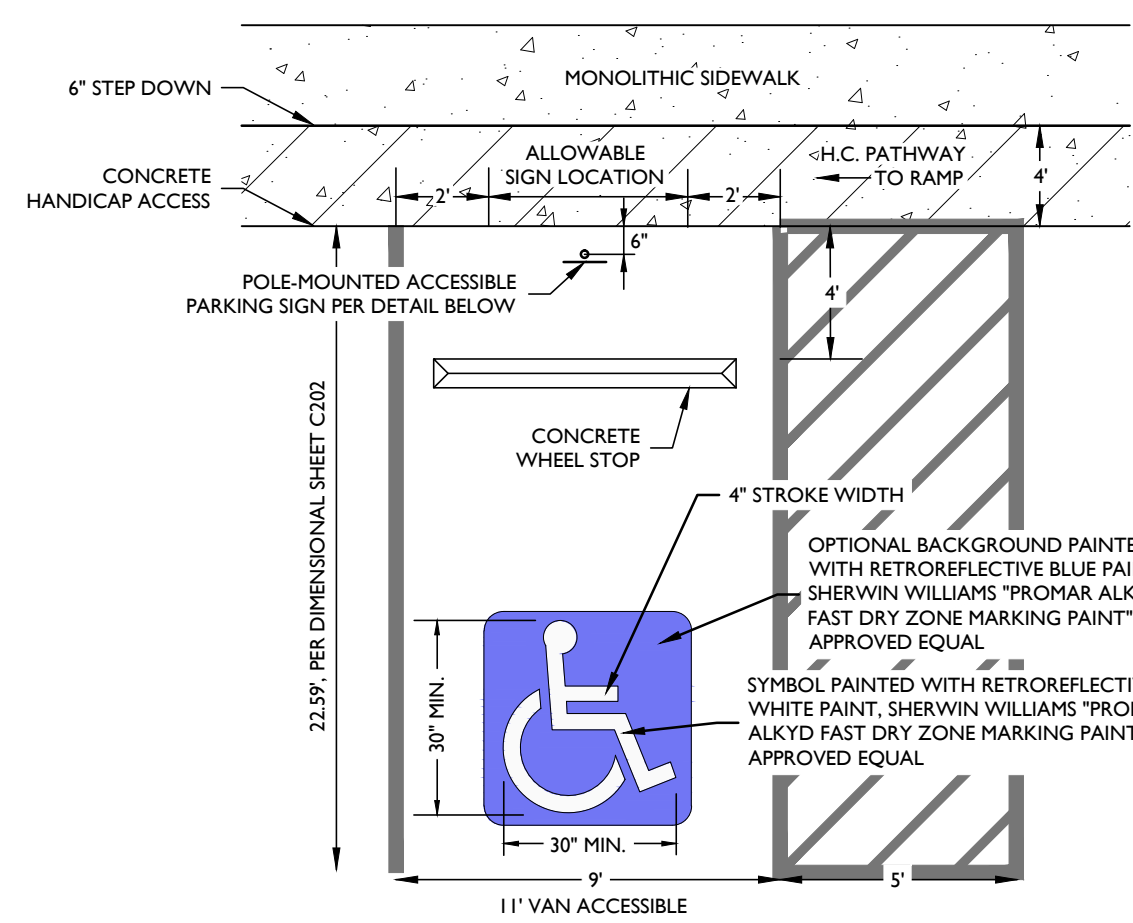

**10 ACCESSIBLE SPACE MARKING "A"**  
OR APPROVED EQUAL. N.T.S.

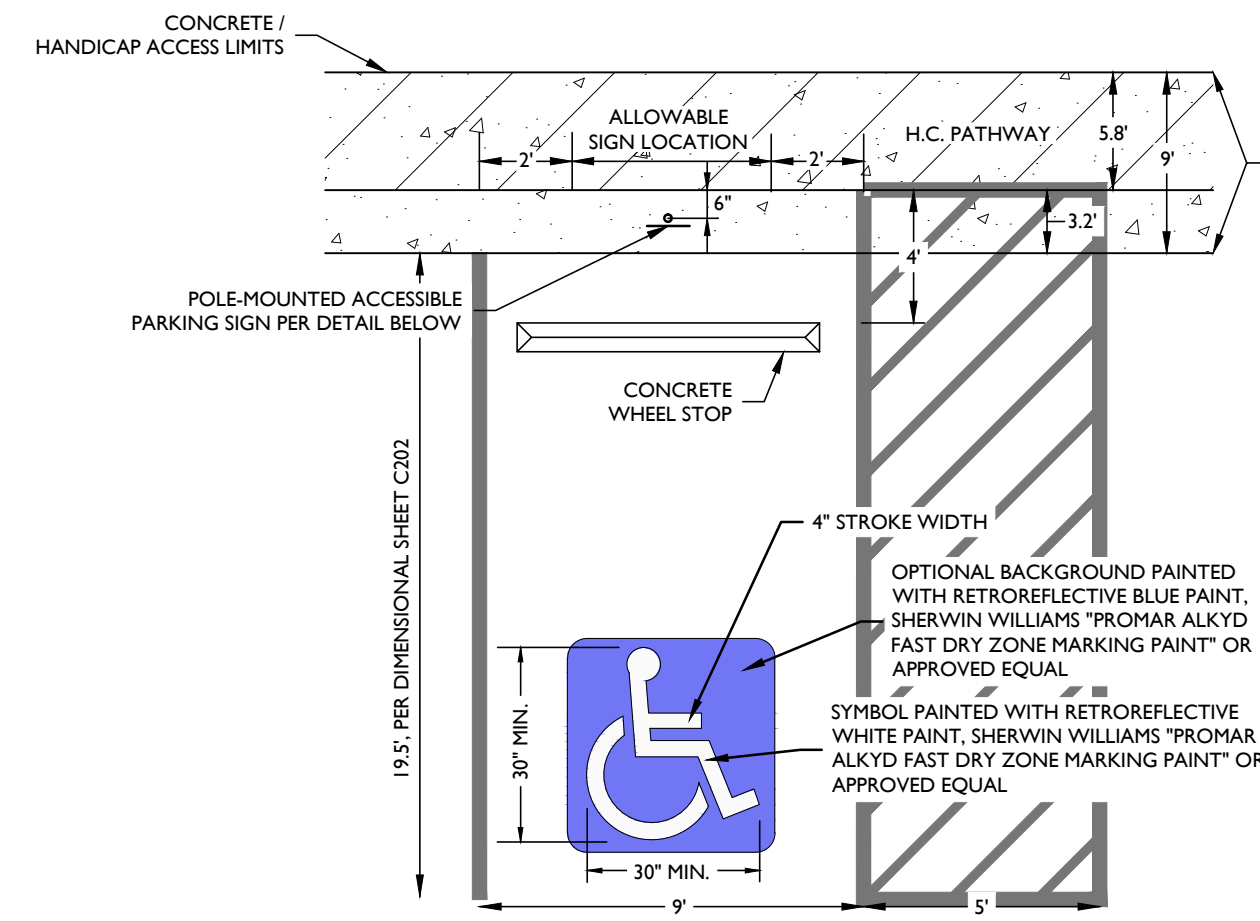

**11 ACCESSIBLE SPACE MARKING "B"**  
OR APPROVED EQUAL. N.T.S.

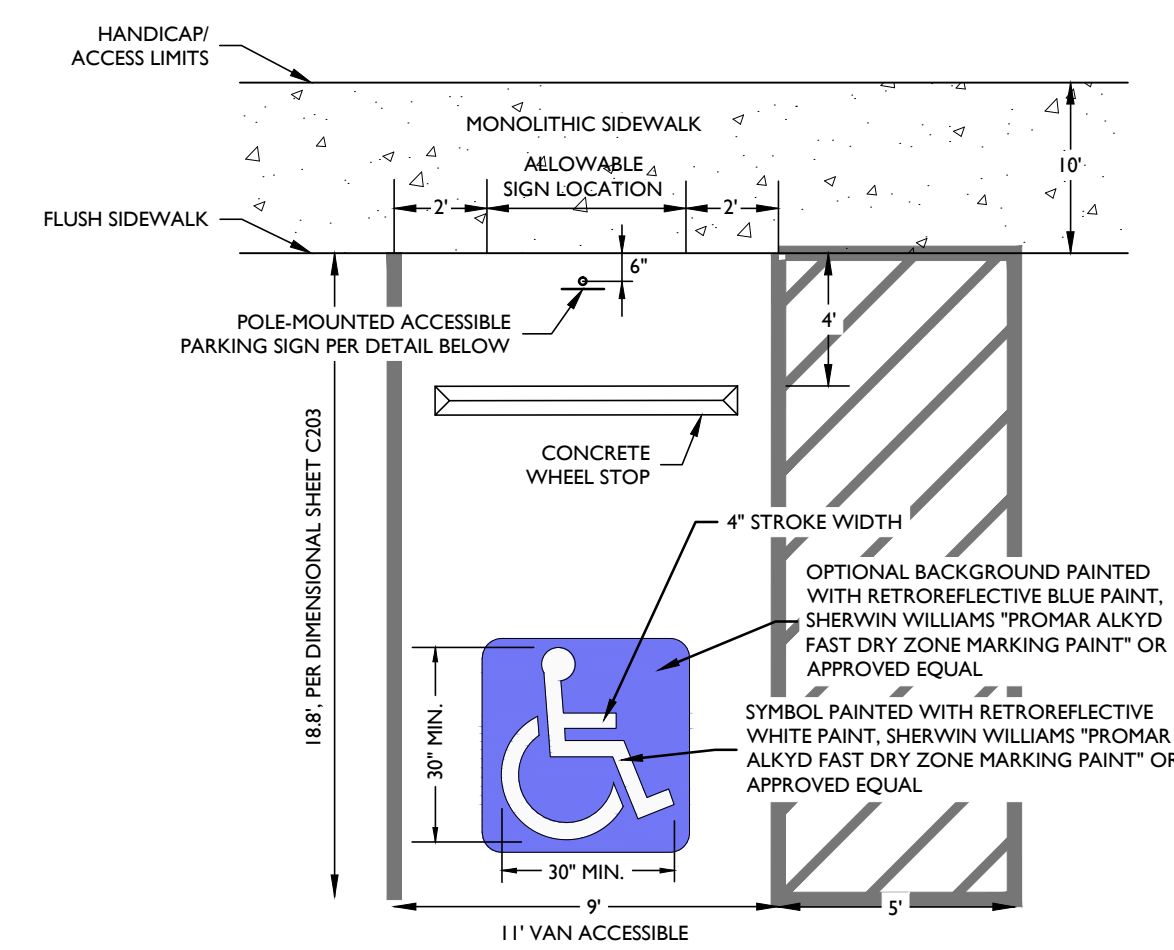

**12 ACCESSIBLE SPACE MARKING "C"**  
OR APPROVED EQUAL. N.T.S.

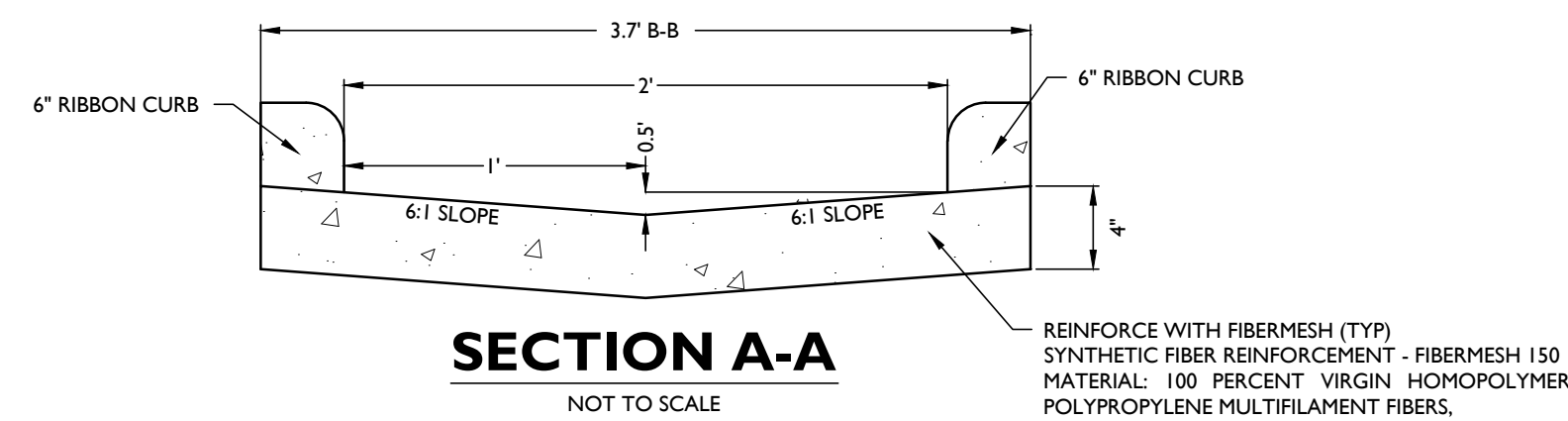

**13 FLUME DETAIL**  
OR APPROVED EQUAL. N.T.S.

REINFORCE WITH FIBERMESH (TYP)  
SYNTHETIC FIBER REINFORCEMENT - FIBERMESH 150  
MATERIAL: 100 PERCENT VIRGIN HOMOPOLYMER  
POLYPROPYLENE MULTIFILAMENT FIBERS,  
CONTAINING NO REPROCESSED OLEFIN  
MATERIALS.  
CONFORMANCE: ASTM C 1116, TYPE III  
APPLICATION RATE: 1.5 POUNDS PER CUBIC YARD  
OF CONCRETE (OR APPROVED EQUAL)

DATE	
APPR.	
BY	
REGIONS	

DRAWN BY: TDE	PERMIT
CHECKED BY: ALM	
APPROVED BY: ALM	
DATE: 05/19/2017	
JOB: 2015-0071	

**PAVING DETAILS**  
**CINERGY CINEMAS**  
BEING A 9.7 TRACT OUT OF LOT 2, BLOCK 2, SECTION 63, BS&F SURVEY, CITY OF AMARILLO, POTTER COUNTY, TEXAS.

*Andrew L. Mellen*  
ANDREW L. MELLEN  
106572  
LICENSED PROFESSIONAL ENGINEER  
05/15/2017